

COMPACT
SERIES

COMPACT SERIES
IRONING SYSTEM

5in1 STANDARD
MULTILINE

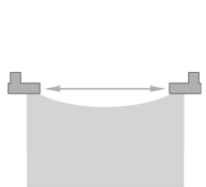

Introduction

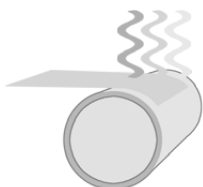

Drying



Ironing

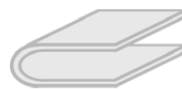

Folding

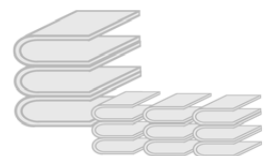

Stacking/Stocking



GIRBAU

LAUNDRY EQUIPMENT

Compact series ironing system

NEW TIMES CALL FOR NEW RESPONSES

COMPACT 600/30/33
COMPACT 800/30/33
COMPACT 1200/33



A HOST OF BENEFITS



COMPACT

A System that makes it possible to integrate five different functions: **Feeding, drying, ironing, folding and stacking** in a single unit. Synchronisation and ease of operation are in the Compact ironing system's DNA.



SPACE

With Compact, less is more. In very little space, it is possible to have a professional ironing system for high levels of production.



PRODUCTIVITY

Everything in the system is designed to increase productivity: only one person is required to operate the machine, the suction feeding table makes it possible to release the article of linen quickly without having to hold it. A larger ironing surface means high production and savings in the drying process.

CHANGING IN ORDER TO IMPROVE

Compact sprang from Girbau's proactive attitude in believing that changes are made in order to improve.

More and more laundries with space or accessibility problems require an ironing system prepared for high productions.

Compact is Girbau's response: new requirements, new solutions.





MULTIFUNCTION IN ESSENCE

Multi-functionality is a concept that arises when there is a need for space and to improve the return on investment. When a single product allows us to enjoy the same functions that previously required many products at the same time, multi-functionality acquires its full meaning.

That is the essence of Compact: five functions in one single machine.

The benefits intrinsic to multi-functionality can be seen clearly in this ironing system.

GIRBAU

5in1

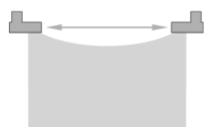

FEEDING

Compact makes it possible to adjust the feeding in a versatile way, with 1 or 2 people, to respond to the needs of each of your customers.



FOLDING

It makes it possible to fold up to 3 cross-folds on 1 line, plus the possibility of 2 cross-folds in 2 lines.



DRYING

The heat output of the Compact system makes it possible to iron the clothes directly without needing to pass previously through the dryer. Thus, it not only saves time, but particularly the energy invested in the process of drying (one of the most expensive laundry processes).

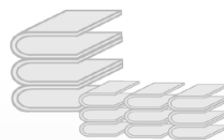

STACKING/STOCKING

The stacker's exclusive design ensures a good stacking quality.



IRONING

It ensures a finish of exceptional quality as a result of the treatment of the roller surface and the interwoven straps.

MINIMUM 20m² OCCUPIED / IDEAL 34m²

Space is one of the arguments that sets the Compact system apart. The minimum operating space is only 20m² although preferably and ideally it should be 34m².

Industrial ironing system is now possible for all those who until now had to reject this option due to space problems.

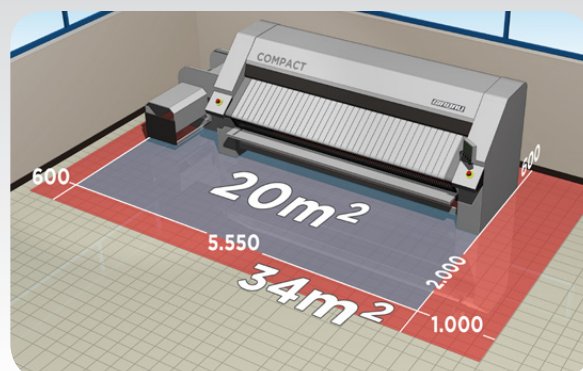

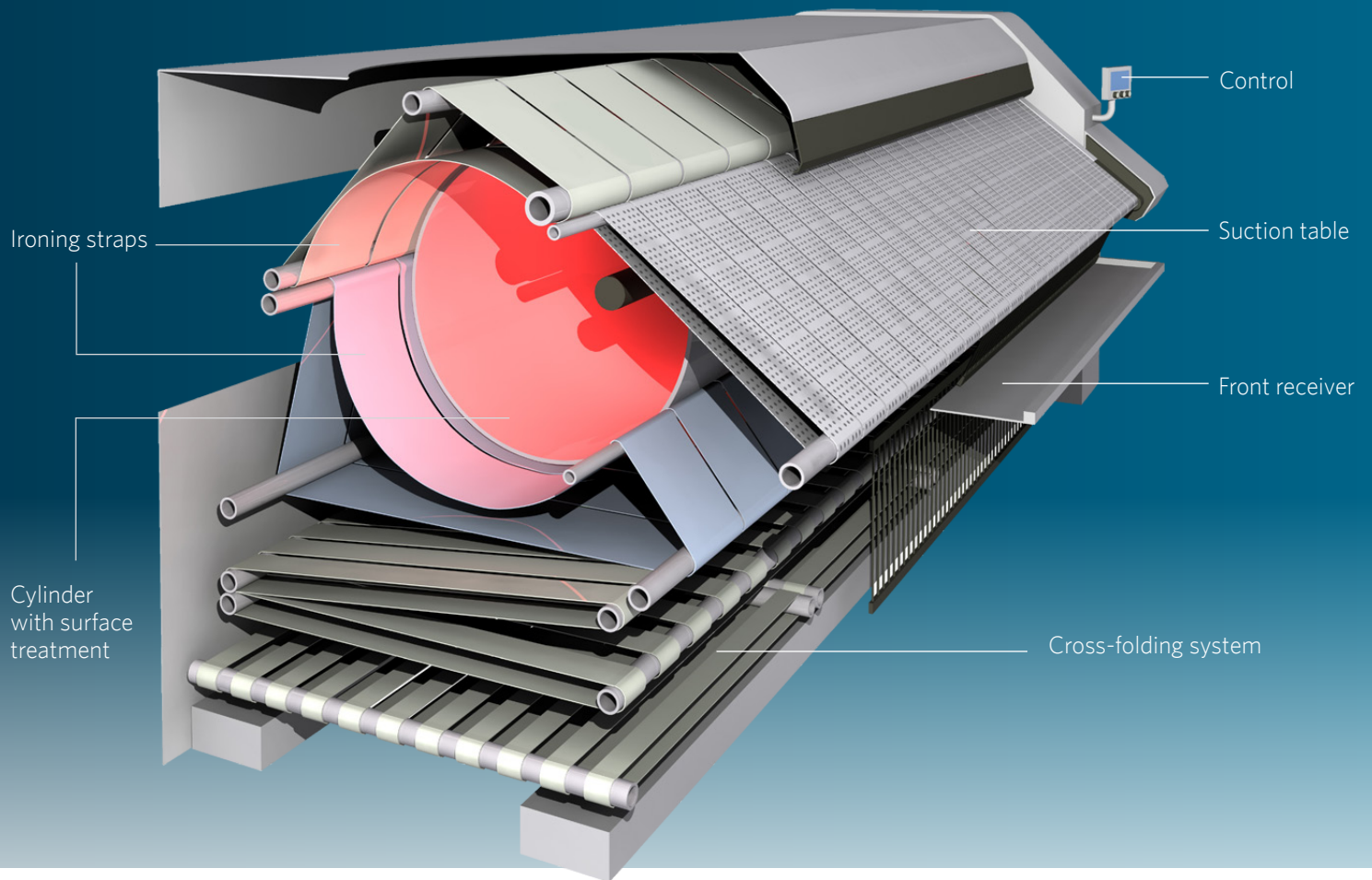

ERGONOMICS

Working with the Compact System is easy and ergonomic. The feeding table has a very extensive surface area. All that needs to be done is to extend the initial part of the article and the suction system helps to position it and hold it firmly in place so that it is well spread out, thereby avoiding the formation of creases during ironing.



FINISHING QUALITY

The final ironing quality is achieved by means of different variables. On the one hand, the linen is in contact with the surface of the roller for longer (the linen passes over 270° of the total of the cylinder). In addition, the **interwoven arrangement** of the two strap circuits prevents any marks from transferring to the linen.



CARING AND GENTLE TREATMENT OF THE FABRIC

In addition to high-quality ironing, the treatment applied to the Compact cylinder ensures delicate care, thereby extending the life of the fabric.



VERSATILITY FOR EACH SECTOR

HOTELS, HOSPITALS, CLINICS, ETC. MEDIUM-SIZED LAUNDRIES FOCUSED ON GROWTH

The Compact System is chameleonic. Its modularity and versatility means that it can fit into all those laundries with little space that need high ironing productions.

Hotels or establishments with centralised laundries can overcome obstacles such as difficult access, limitations of space or restricted locations since the machine can be mounted in the same workplace.

Hospitals, clinics or centres for the elderly are other types of businesses that can benefit from an internal industrial laundry with the Compact System, without this meaning higher operator costs or requiring a large work area.

Finally, **medium-sized industrial laundries** that are growth-oriented can count on the Compact System, offering as it does industrial production without having to invest in an ironing system that requires a larger premises.

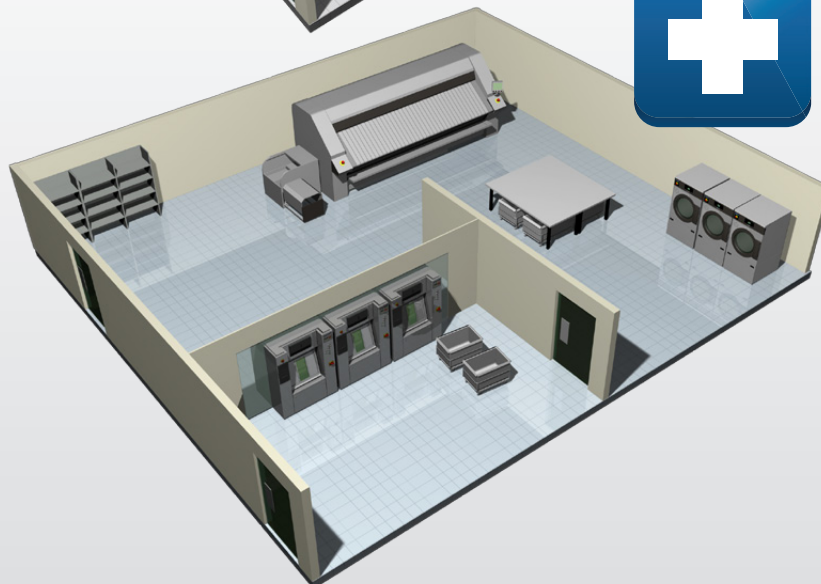



FEEDER

FEEDING CLAMPS

The feeding clamps ensure that the article is always well centred so that during the subsequent folding the folds and stacking are impeccable.

Safe and ergonomic, the Compact System's clamps make it possible for a single person to feed in large-sized articles of linen.



DE-CREASING BRUSHES

A system of brushes ensures that the article of linen is well stretched out, both on the sides and the last part to be fed in. A proper stretching prevents creases from forming later.



FEEDING LANES

The Compact can be configured for 1, 2 or 4 lanes, with 1 lane for sheets, 2 for table linen and 4 for small articles (such as napkins or pillowcases).

MANUAL

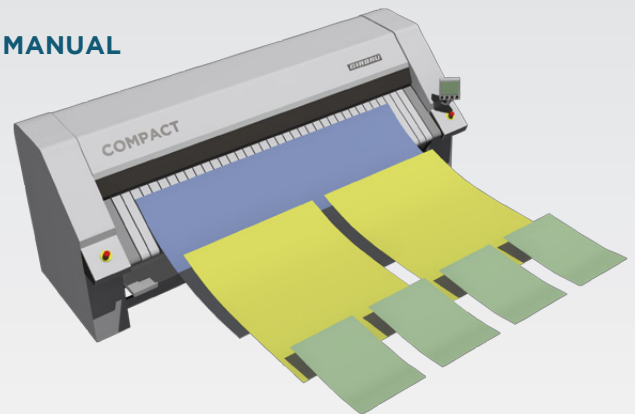

AUTOMATIC (with feeder)

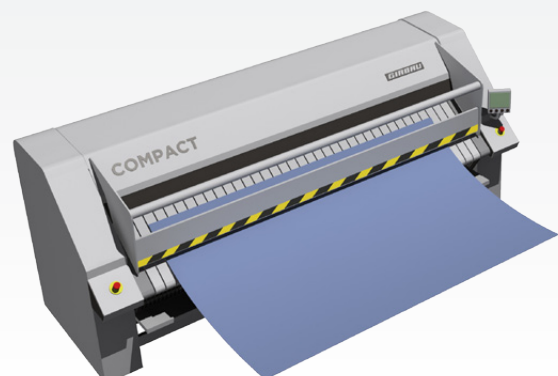

FOLDING

STANDARD

PRIMARY

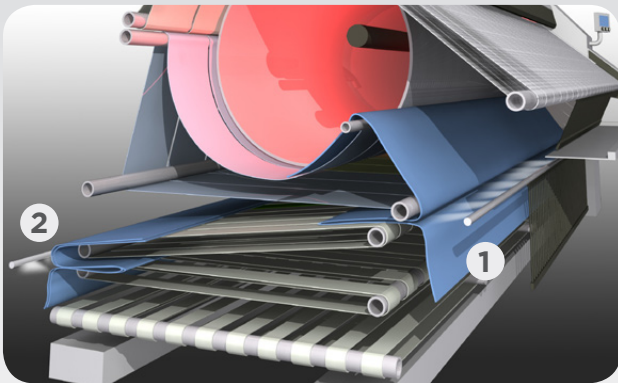

1 LINE

Performs two primary (lengthwise) folds. Straightforward and reliable folding, adapted to the majority of needs. Cost effective and economical. Suitable for articles of up to 3.6 metres long (folded size 900mm). Performs one or two primary folds on **1 line**.



CROSS

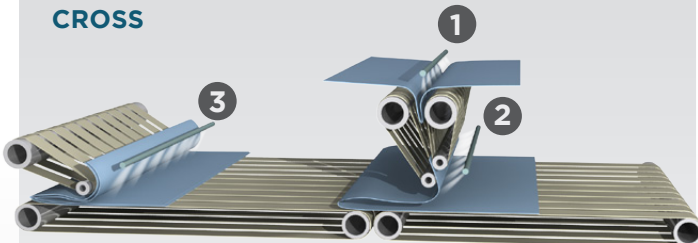

1 LANE

With the Standard version the automatic cross fold is performed on a single line. Up to 3 folds can be performed. These folds are performed with air of by reversing the belts.

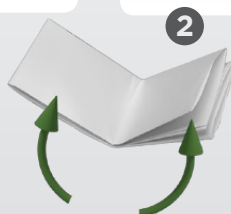
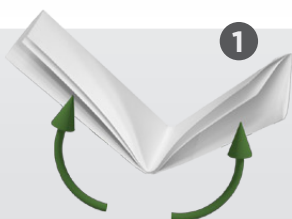

MULTILINE

PRIMARY

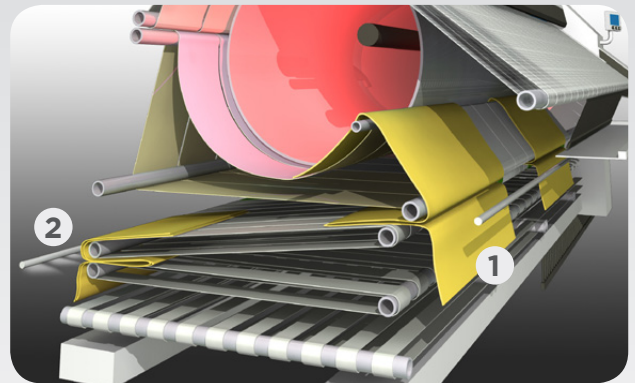

2 LINES

Performs two primary (lengthwise) folds. Straightforward and reliable folding, adapted to the majority of needs. Cost effective and economical. Suitable for articles of up to 3.6 metres long (folded size 900mm). Performs one or two primary folds on **2 lines**.



CROSS

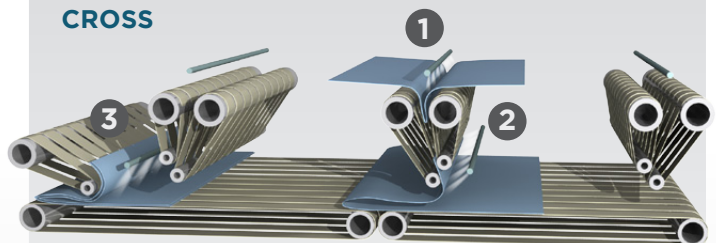

MULTILINE

With the Multiline version, the cross-fold is performed on 1 line or on 2 lines automatically. Up to 3 cross-folds can be performed on one line and up to 2 cross-folds on 2 lines. These folds are performed with air of by reversing the belts.

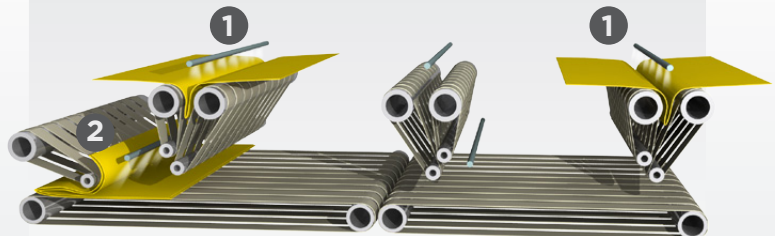



FLEXIBILITY

HEATING

The main aim of the Compact System is to overcome barriers and succeed in adapting to the needs of laundries that could not otherwise access a conventional industrial ironing system.

Heating is available in **gas, electric or steam**.

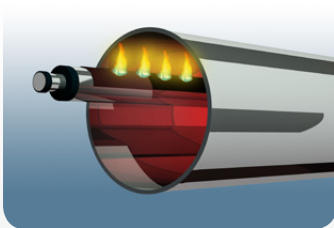

GAS

A clean, high performance system that is environmentally friendly.

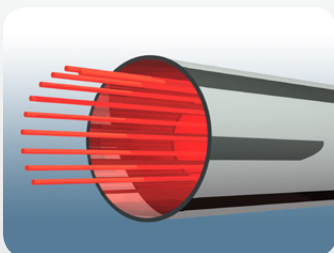

ELECTRIC

Electric heating is designed to adapt to our clients' demands. Having an electric industrial Ironing System is NOT synonymous with high energy consumption for Compact.

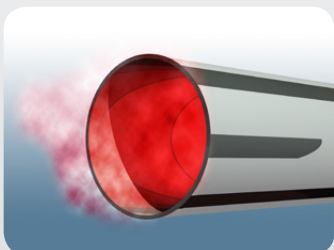

STEAM

Steam continues to be a requirement for many laundries. Compact is also available with this heating system..



3 INDEPENDENT HEAT ZONES

The Compact System is highly efficient. It maintains three separate temperature zones and has a system that modulates the heat of the roller, thereby ensuring that it provides the heat necessary at all times for maximum efficiency. The independent modulation of the three heat zones makes it possible to save up to 30% on energy.

1 BURNER

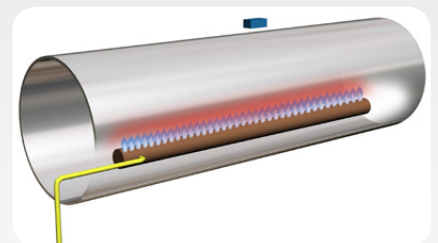

3 BURNERS

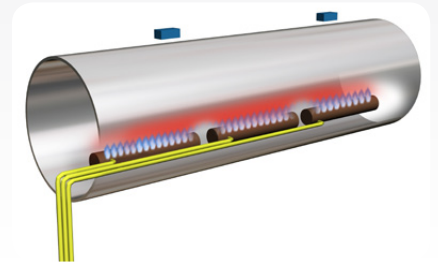



WHEREVER YOU LIKE “KNOCK DOWN” Version

EASE OF INSTALLATION

In an effort to overcome barriers, they can be mounted in areas that are inaccessible, for example laundries located in the centre of many hotels. Compact can be dispatched dismantled into modules that our technical service assembles inside the laundry. Its bolted dismantlable structure makes it possible to access your laundry.

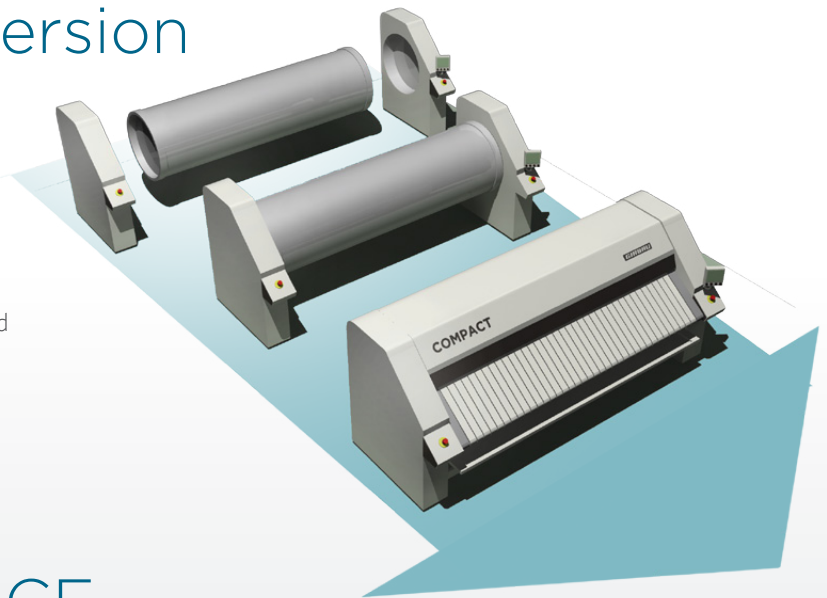

EASY MAINTENANCE

ACCESSIBILITY FOR MAINTENANCE

The large internal areas that its structure leaves mean that maintenance work can be carried out very easily.





CONTROL, FLEXIBILITY AND SAFETY

EASY PROGRAMMING

Adjusting programming to the needs of each client is one of the keys to success, both in terms of the final result for the client, and for their laundry, which will be proportionately more efficient with good programming.

The Compact System's control with colour touch screen is extremely intuitive and easy to program.

With the possibility of creating multiple programs, it makes it possible to identify the name of the customer in order to assist the process.

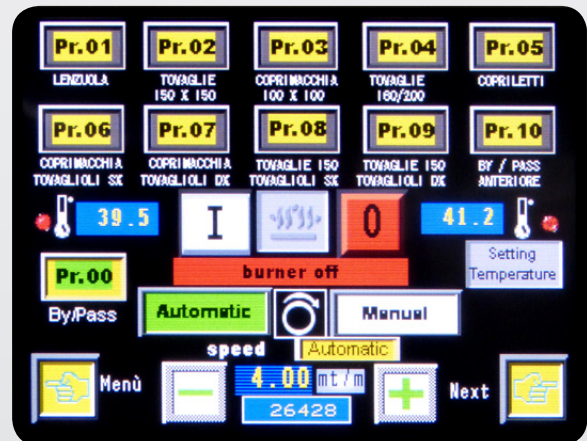

VISUAL MONITORING OF INCIDENTS

The Compact System's control monitor displays the location of incidents, should they occur, graphically and visually, thereby saving time and preventing any impact on productivity.

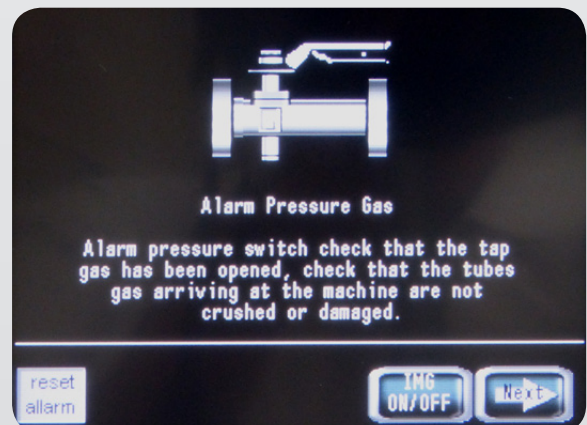

COMPACT SERIES IRONING SYSTEM



MODEL		60.26	60.33	80.26	80.33	120.33
IRONING						
Roller diameter	mm (in)	600 (23.6)		800 (31.5)		1200 (47.2)
A Useful width	mm (in)	2600 (102.3)	3300 (129.8)	2600 (102.3)	3300 (129.8)	
Operating speed	m/min (ft/min)	4 - 12 (13.12-39.36)		4 - 15 (13.12-49.2)		4 - 25 (13.12-82)
Ironing surface area	m ² (sq ft)	3,4 (36.6)	4,2 (45.2)	5,1 (54.8)	6,5 (69.9)	11,9 (128)
Theoretical production:*	kg/h (lbs/h)	140 (308.7)	170 (374.8)	180 (396.8)	230 (507.1)	380 (837.8)
Max. water evaporation**	l/h (Usgal/h)	70 (18.6)	85 (22.6)	90 (23.9)	120 (31.8)	220 (58.4)

FOLDING

1 line - primary folds		1 - 2
1 line - cross-folds		1 - 2 - 3
2 lines - primary folds		1 - 2
2 2 lines - cross-folds		1 - 2

CONSUMPTIONS

Natural gas (9,500 kcal)	m ³ /h (c.f.m.)	6,4 (3.8)	8,4 (4.9)	8,8 (5.2)	13,5 (7.9)	27 (15.9)
Propane gas (12,000 kcal)	kg/h (lbs/h)	5,7 (12.6)	6,7 (14.8)	7,5 (16.5)	9 (19.8)	14,5 (32)
Steam (12 bar)	kg/h (lbs/h)	100 (220.5)	120 (264.6)	135 (297.6)	160 (352.7)	320 (705.5)
Compressed air (8 bar)	Nl/h	25000				
Electrical voltage (V 400/240) ***	kW	3,1	3,4	4,1		4,5
Electric heating.	kW	50	55	60	65	95

TECHNICAL DATA

Total width **** L	mm (in)	4750 (186.9)	5380 (211.7)	4855 (191)	5550 (218.4)	
Height H	mm (in)	1800 (70.8)		2050 (80.7)		2300 (90.5)
Depth P	mm (in)	2480 (97.6)		2670 (105.1)		2900 (114.1)
Stacker width LP	mm (in)	1270 (50)				
Absorption (V 400/240)	A	8,8/15,0		9,8/16,7		
Suction	m ³ /h (c.f.m.)	2x1100 (2x647)				2x1500 (2x881)
Evacuation diameter	mm (in)	2x120 (2x4.7)				2x140 (2x5.5)
Net weight	kg (lbs)	3100 (6834.4)	3400 (7495.8)	3300 (7275.4)	3700 (8157.2)	4100 (9039.1)
Noise level	dB/A	<60				

GIRBAU S.A. reserves the right to change specifications without notice

* Residual moisture of the 50% max.

** On using all the useful width

*** C Steam Heating: 400V/240V-3 Ph+N+T-50 Hz / Gas Heating: 400V/240V-3 Ph+N+T-50 Hz

**** Total steam width: 5750 mm

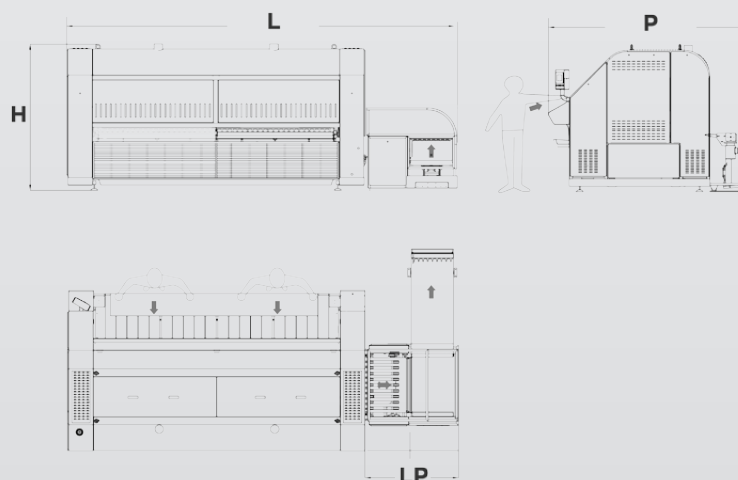



E&B

EASY & BEST SOLUTIONS

EASY AND SUSTAINABLE SOLUTIONS

We propose a new way of working, aimed at achieving the best solution in the easiest way possible.

Just let us know your production requirements. We will take care of the rest.

Easy and best



Ver video

BRANCHES

- Argentina - Buenos Aires -Tel. +54-1 149017600 - girbauargentina@girbau.com.ar
- Australia - Castle Hill, Sydney - Tel. +61298940399 - sales@girbau.com.au
- Brazil - Sao Paulo - Tel. +55 11-29820446 - girbaudobrasil@girbau.com.br
- China - Shenzhen & Hong Kong - Tel. +86-755-8211 1330 - info@girbau.com.cn
- Cuba - La Habana - Tel. (+53-7) 8662071 al 73 - girbau@girbau.co.cu
- Dominican Rep. - Punta Cana - Tel. +1 809-959-0615 - info@girbau.do
- France - Roissy (Paris) - Tel. +33 1-49388585 - info@girbau.fr
- Germany - Hannover - Tel. +49-511 60099389 - girbau@girbau.de
- Italy - Marcon (VE) - Tel. +39 0418654330 - info@girbau.it
- Portugal - Porto - Tel. +351 22 3758909 - vendasportugal@girbau.pt
- U.A.E. - Dubai - Tel. +971 4-8839951 - sales@girbau.ae
- U.K. - Hitchin - Tel. +44(0)-1462 427780 - info@girbau.co.uk
- U.S.A. - Oshkosh, Wi & Los Angeles, Ca - Tel. +1(920) 2318222 - info@continentalgirbau.com

HEADQUARTERS

GIRBAU, S.A. Ctra de Manlleu, km. 1 - 08500 Vic (Barcelona) Spain - www.girbau.com
 Tel. (+34) 93 886 2219 - Fax (+34) 93 886 0785 - sales@girbau.es

